

Flamgard-Plus

Flameproof Flammable Gas Detector

with Non-intrusive One-man
Calibration

Plus

Installation, operating and maintenance
instructions, MO7192, Issue 6 02/2011

1. INTRODUCTION

1.1 Product overview

Flamgard Plus is a flameproof flammable gas detector suitable for use in zone 1 or 2 hazardous areas. It is designed to detect flammable gas, present in ambient air, at concentrations not exceeding the Lower Explosive Limit (LEL) of the target gas for which it is calibrated. A local display and magnetically operated switches allow non-intrusive one-man calibration without a hot work permit. Powered by 24 V dc (nominally) Flamgard-Plus provides a 4-20 mA signal (sink or source) proportional to the gas concentration and can also be fitted with optional alarm and fault relays. For a list of flammable gases that can be detected, please contact Crowcon.

1.2 Product description

Flamgard Plus comprises four parts; 96HD sensor housing, junction box, amplifier and terminal board. Diagram 1 details Flamgard Plus. The overall assembly is certified EEx d IIC T6 in Europe and Class 1, Zones 1&2 AEx d IIC T6 in the USA.

The 96HD sensor housing is a modular stainless steel assembly that dismantles to allow plug in pellistor sensors to be replaced easily (see Diagram 4). The assembly screws into an M20 entry on the junction box.

The junction box is manufactured from marine grade alloy and is supplied with 2 x M20 (1/2" NPT for USA) cable entries for customer use. Alternative cable entries are available from Crowcon.

The amplifier plugs into the terminal board, and is held in place by two captive screws. The amplifier provides power to the pellistor sensor, local display and controls, and a 4-20 mA signal proportional to the gas concentration for connection to a control panel. To remove, turn screws anti-clockwise and use them to pull amplifier out of the enclosure.

All electrical connections are made via the terminal board mounted in the base of the junction box (see Diagram 2). Optional alarm relays (AL1 & AL2) and one fault relay (FAULT) are mounted on the terminal board which may be used to drive local warning devices or connect Flamgard-Plus to a control panel.

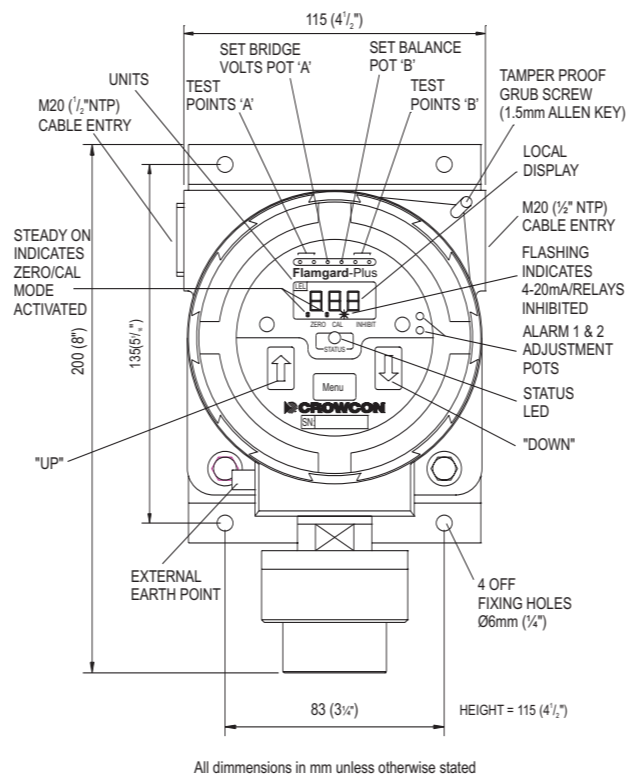

Diagram 1: Flamgard Plus general arrangement

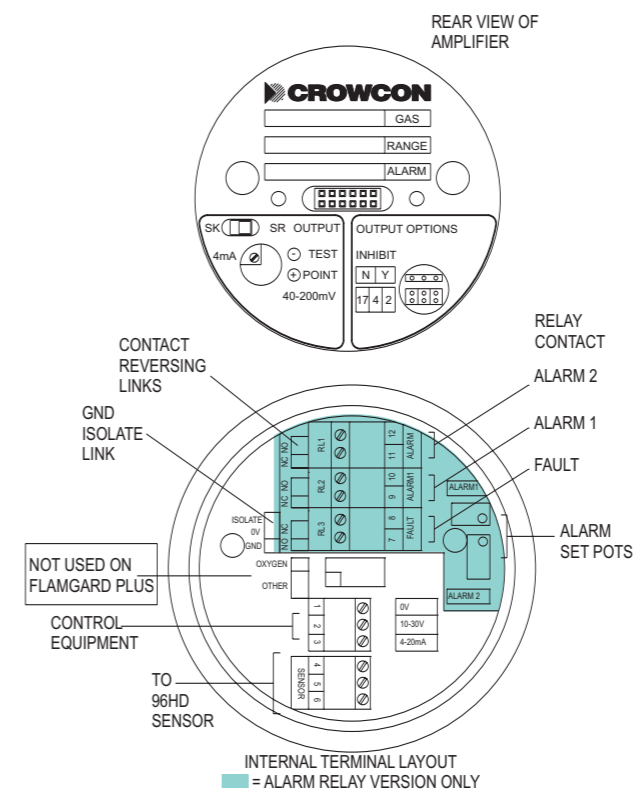

Diagram 2: Terminal and amplifier layouts

1.3 Status Indication

Flamgard Plus includes a local display and status LED, visible through the junction box window. This is shown in Diagram 1.

The display shows the current flammable gas concentration in the range 0-100%LEL and current mode of operation ie NORMAL, ZERO or CAL. The LED shows the current alarm state of the detector. This is summarised in Table 1.

| Operational state | LED indication | 4-20mA outputs* | Relay states* | Comment* |
|----------------------------|----------------|---|---|---|
| Normal operation | Steady green | 4 to 7.2mA | AL1 - Off AL2 - Off FAULT - On | 0 to 20% LEL |
| Normal operation (Alarm 1) | Steady red | 7.2 to 10.4mA | AL1 - On AL2 - Off FAULT - On | 20 to 40% LEL |
| Normal operation (Alarm 2) | Flashing red | 10.4 to 20mA | AL1 - On AL2 - On FAULT - On | 40 to 100% LEL |
| Over-range | Flashing red | 24mA (clamp) | AL1 - On AL2 - On FAULT - On | >100% LEL Display back-light flashes |
| Zero/calibration mode | Flashing green | Configuration dependent (see section 2) | Configuration dependent (see section 2) | Latched until reset via 'MENU' |
| Detector fault | Steady amber | 0mA | AL1 - Off AL2 - Off FAULT - Off | |

*As standard, AL1 = 20%LEL and AL2 = 40%LEL

■ = RELAY VERSION ONLY

Table 1: LED status indicator summary.

2. DETECTOR CONFIGURATION

2.1 Standard configuration

As standard, Flamgard-Plus is factory set as follows:

| | |
|---|---|
| Current source with | 0 mA = Fault |
| | 2 mA = Inhibit ie. Zero/Cal mode |
| | 4-20 mA = Normal operation |
| | 24 mA = Over-range clamp |
| AL1 relay | Alarm level 1 set to 20%LEL Normally de-energised, energising on alarm Contact normally open (NO), closing on alarm |
| AL2 relay | Alarm level 2 set to 40%LEL Normally de-energised, energising on alarm Contact normally open (NO), closing on alarm |
| FAULT relay | Normally energised, de-energised on fault Contact normally closed (NC), opening on fault |
| Alarm/fault relays automatically reset when alarm or fault has cleared. | |
| INHIBIT | Normally selected, ie. when CAL/ZERO selected current output is forced to 2mA and relays are held in normal/no alarm state. |

Location of links are shown in Diagram 2.

2.2 4-20mA options

To change current source output to sink, set switch to 'SK' position. To change Inhibit from 2 mA to 4 mA, fit link to '4' position.

2.3 Relay options

To change AL1 or AL2 relay from NO to NC, fit link in the 'NC' position. To change FAULT relay from NC to NO, fit link in the "NO" position.

2.4 Inhibit options

To not inhibit 4-20 mA signal and relays, fit link to 'N' and link to '4'.

3. INSTALLATION

WARNING

Flamgard Plus is designed for use in Zone 1 and 2 hazardous areas and is certified EEx d IIC T6 (AEx d IIC T6 in USA). Installation must be in accordance with the recognised standards of the appropriate authority in the country concerned. For more information contact Crowcon. Prior to carrying out any work ensure local regulations and site procedures are followed.

3.1 Location

There are no rules which dictate the siting and location of detectors, however, considerable guidance is available from BS EN 50073:1999 'British Standard Code of Practice for the Selection, Installation, Use and Maintenance of Apparatus for the Detection and Measurement of Combustible Gases or Oxygen.' In the USA refer to the National Electrical Code (NEC 1999). Similar international codes of practice may be used where applicable. In addition certain regulatory bodies publish specifications giving minimum gas detection requirements for specific applications.

The detector should be mounted where the gas is most likely to be present. The following points should be noted when locating flammable gas detectors:

- To detect gases which are lighter than air (eg methane), detectors should be mounted at high level and Crowcon recommend the use of a collector cone (Part No. C01051).
- To detect heavier than air gases (eg butane), detectors should be mounted at low level.
- When locating detectors consider the possible damage caused by natural events e.g. rain or flooding. For detectors mounted outdoors Crowcon recommend the use of a Weatherproof Cap (Part No. C01442).
- Consider ease of access for functional testing and servicing.
- Consider how the escaping gas may behave due to natural or forced air currents. Mount detectors in ventilation ducts if appropriate.

- Consider the process conditions. Butane, for instance is normally heavier than air, but if released from a process line which is at an elevated temperature and/or under pressure, the gas may rise rather than fall.

The placement of detectors should be determined following advice of experts having specialist knowledge of gas dispersion, the plant processing equipment as well as safety and engineering issues. The agreement reached on the locations of sensors should be recorded. Crowcon would be pleased to assist in the selection and siting of gas detectors.

3.2 Mounting

The mounting detail of Flamgard Plus is given in Diagram 1. Flamgard Plus should be installed at the designated location with the detector pointing down. This ensures that dust or water will not collect on the sinter and stop gas entering the detector.

3.3 Cabling requirement

Cabling to Flamgard Plus must be in accordance with the recognised standards of the appropriate authority in the country concerned and meet the electrical requirements of the detector. Crowcon recommend the use of steel wire armoured (SWA) cable and suitable explosion proof glands must be used. Alternative cabling techniques, such as steel conduit, may be acceptable provided appropriate standards are met.

Flamgard Plus requires a dc supply of 12-30 V at up to 210 mA. Ensure the minimum dc supply of 12 V is observed at the detector, taking into account the voltage drop due to cable resistance.

For example, a nominal dc supply at the control panel of 24 V has a guaranteed minimum supply of 20 V. The maximum voltage drop allowed is therefore 8 V. Flamgard Plus can demand up to 210 mA and so the maximum loop resistance allowed is 38 Ohms. A 1.5 mm² cable will typically allow cable runs up to 1500m.

Table 2 shows maximum cable distances given typical cable parameters.

| CSA mm ² (awg) | Resistance (Ohms per km) | | Max. distance m (ft) |
|---------------------------|--------------------------|------|----------------------|
| | Cable | Loop | |
| 1.0 (17) | 18.1 | 36.2 | 1000 (3280) |
| 1.5 (15) | 12.1 | 24.2 | 1500 (4920) |

Table 2: Maximum cable distances for typical cables

Acceptable cross sectional area of cable is 0.5 to 1.5 mm². Table 2 provides guidance only, actual cable parameters for each application should be used to calculate maximum cable distances.

3.4 Electrical connections

All connections are made via the terminal board mounted in the base of the junction box (see Diagram 2). The 3 wires from the 96HD are colour coded and should be terminated in the corresponding colour coded terminal (terminals 4, 5 & 6). Terminals 1 (0 Vdc), 2 (12-30 Vdc) and 3 (4-20mA signal) are connected to the control equipment. Flamgard Plus is factory set as a 4-20 mA source device unless specified otherwise when ordering (see Section 2 to change configuration). Diagram 3 summarises the electrical connections.

Note: The junction box and cable armour must be earthed at the detector or control panel to limit the effect of radio frequency interference and to maintain electrical safety.

Note: The junction box for the Flamgard Plus is manufactured from marine-grade alloy, and has a powder-coated finish. Care should be taken during installation to protect the painted finish, as use in saline environments could result in paint flaking off from damaged junction boxes. This in no way compromises the performance of the detector, as the marine-grade alloy junction box is approved for use in offshore environments.

Web site: www.crowcon.com
Email: sales@crowcon.com.sg
Tel: +65 6745 2936
Singapore 128383
#06-20 Pantech Industrial Complex
Block 194 Pandan Loop
Crowcon Detection Instruments Ltd
Singapore Office
Web site: www.crowcon.com
Email: salesusa@crowcon.com
Tel: +1 859 957 1039
+1 859 957 1044
1-800-5-CROWCON
Kentucky 41018-1845 USA
Ehanger,
21 Kenton Lands Road,
Crowcon Detection Instruments Ltd
USA Office
Web site: www.crowcon.com
Email: eu@crowcon.com
Tel: +31 10 421 1232
+31 10 421 1232
Vlaanderen 129
3068JG, Rotterdam Netherlands
Crowcon Detection Instruments Ltd
Rotterdam Office
Web site: www.crowcon.com
Email: sales@crowcon.com
Tel: +44 (0) 1235 557749
+44 (0) 1235 557700
Oxfordshire OX14 1DY, UK
Abingdon
Abingdon Business Park
2 Blacklands Way
Crowcon Detection Instruments Ltd
UK Office



A HALMA COMPANY

3. INSTALLATION (continued)

All electrical connections to the optional relays are made via the 6-way terminal block on the terminal board in the base of the junction box (see Diagram 2). The relay contacts are rated 1 A @ 30 Vdc.

WARNING
Prior to carrying out any work ensure local regulations and site procedures are followed. Never attempt to open the detector or junction box when flammable gas is present. Ensure that the associated control panel is inhibited so as to prevent false alarms.

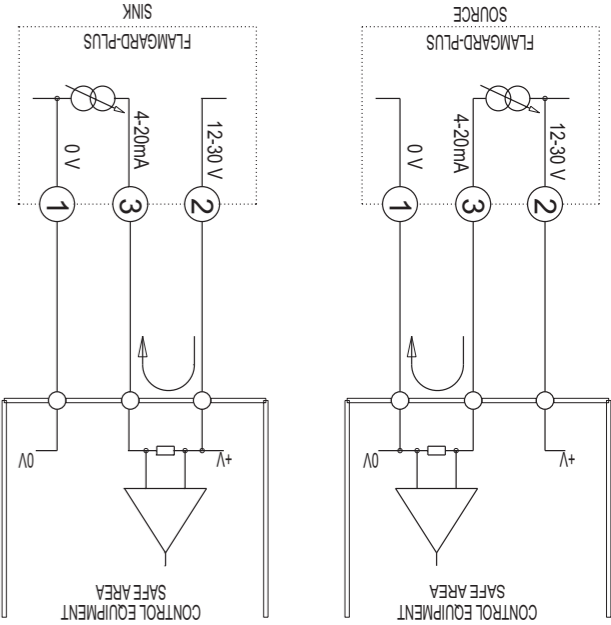

Diagram 3: Electrical connections to Flamgard Plus

9

4. OPERATION (continued)

4.4 Changing Alarm Levels (Relay Version Only)

WARNING
This work should be carried out by Crowcon or an approved service centre unless suitable training has been received. Before attempting to change alarm levels ensure the detector is in fresh air and no flammable gas is present.

- Switch off and isolate power to the detector requiring attention.
- Open the junction box of the detector by loosening the tamper proof grub screw and removing the lid by rotating it anti-clockwise.
- Remove the amplifier from the terminal board.
- Ensure that the 'INHIBIT' link is set to 'N'.
- Fit the amplifier to the terminal board ensuring that all screws have been secured correctly.
- Apply power to the detector and allow the detector to stabilise.
- Place the end of 'CRO-Mag' over the 'MENU' pad. The decimal point above the word 'ZERO' will illuminate.
- With no flammable gas present at the detector, place the end of the 'CRO-Mag' key over the 'UP' or 'DOWN' arrow pads to make the display read zero.
- Using a DVM measure the voltage across Test Points 'A' and adjust Set Bridge Volts (Pot A) until the DVM reads correctly (see Table 3 for complete list).
- Using a DVM measure the voltage across Test Points 'B' and adjust Set Balance (Pot B) until the DVM reads 0 mV.
- Close the junction box remembering to fasten the tamper proof grub screw into position.
- Follow the Commissioning Procedure given in 4.1.

- Switch off and isolate power to the detector requiring attention.
- Open the junction box of the detector by loosening the tamper proof grub screw and removing the lid by rotating it anti-clockwise.
- Remove the amplifier from the terminal board.
- Ensure that the 'INHIBIT' link is set to 'N'.
- Fit the amplifier to the terminal board ensuring that all screws have been secured correctly.
- Apply power to the detector and allow the detector to stabilise.
- Place the end of 'CRO-Mag' over the 'MENU' pad. The decimal point above the word 'ZERO' will illuminate.
- With no flammable gas present at the detector, place the end of the 'CRO-Mag' key over the 'UP' or 'DOWN' arrow pads to make the display read the desired alarm level.
- Using a long instrument screwdriver, turn the relevant ALARM SET pot mounted on the terminal board (see Diagrams 1 & 2) to adjust the alarm level. Tripping of the ALARM 1 level relay is confirmed by the status LED turning a steady red. Tripping of the ALARM 2 level relay is confirmed by the Status LED flashing red.
- Once the alarm level has been set, place end of 'CRO-Mag' over the 'UP' or 'DOWN' arrow pads and reset the display to read zero.
- Place the end of the 'CRO-Mag' over the 'MENU' pad to return the detector to normal operation, ie. No decimal points displayed, backlight off and the Status LED indicating steady green.

15

4.2 Routine maintenance

- The operational life of the pellistor sensor depends on the application for which it is being used. Such a device should work satisfactorily for up to 5 years in ideal conditions. Site practices will dictate the frequency with which detectors are tested. Crowcon recommend that detectors be gas tested at least every 6 months and re-calibrated as necessary. To recalibrate a detector follow steps given in 4.1.
- Pellistors can suffer from loss of sensitivity when there is a presence of poisons or inhibitors such as silicoes, sulphides, chlorine, lead or halogenated hydrocarbons. Flamgard Plus uses poison resistant compounds are present continuously, we recommend the use of Xgard IR or Irmox. Crowcon's fixed point infrared flammable gas detectors, which are immune to such poisons and inhibitors.
- Place the end of 'CRO-Mag' over the 'MENU' pad. The decimal point above the word 'CAL' will illuminate. Other indications remain unchanged.
- Apply calibration gas to the detector at a flow rate of 0.5 litres/min. Crowcon recommend 50% LEL gas for calibration purposes (contact Crowcon for the supply of calibration gas.)
- Place the end of the 'CRO-Mag' over the MENU pad. The decimal point above the word 'CAL' will illuminate. Other indications remain unchanged.
- Apply calibration gas to the detector at a flow rate of 0.5 litres/min. Crowcon recommend 50% LEL gas for calibration purposes (contact Crowcon for the supply of calibration gas.)
- Leave the detector to stabilise for 1-2 hours.
- Place the end of 'CRO-Mag' over the 'MENU' pad. The decimal point above the word 'CAL' will illuminate. Other indications remain unchanged.
- With no flammable gas present at the detector, place the end of the 'CRO-Mag' key over the 'UP' or 'DOWN' arrow pads to make the display read zero.
- Apply power to the detector. The status LED will show a steady green indicating normal operation.
- Leave the detector to stabilise for 1-2 hours.

11

- Check that the detector operates correctly by applying test gas as necessary.
- Switch off and isolate power to the detector.
- Reset jumpers which may have been changed in step 'd' above.
- Replace the amplifier and close the junction box, ensuring that all screws have been re-fitted correctly.
- Apply power to the detector and allow to stabilise before checking correct operation.
- Re-calibrate if necessary as per section 4.1.

16

4.3 Sensor replacement/servicing of detectors

WARNING
This work should be carried out by Crowcon or an approved service centre unless suitable training has been received.

Flamgard Plus uses the 96HD sensor housing which allows the user to replace the sensors, gaskets and sinter in Diagram 4. The following procedure may be followed when servicing a Flamgard Plus detector.

- Switch off and isolate power to the detector requiring attention.
 - Open the detector junction box by loosening the tamper proof grub screw and removing the lid by rotating it anti-clockwise.
 - Remove the amplifier.
 - Disconnect the 3 sensor wires from the terminal board (terminals 4, 5 & 6).
 - Unscrew the complete 96HD sensor housing from the junction box.
- Note: If a spare 96HD sensor housing complete with new sensor is available ignore steps f to k and return the old 96HD to Crowcon or an approved service centre for repair.**

12

- Open the 96HD sensor housing by removing the four Allen head screws from the Top Cap with a 3mm Allen key.
- Remove the sensor from the Top Cap PCB. Flammable sensors have an extra black sleeve which may be separate from the sensor. This is normal and the sleeve may be re-used.
- Fit the replacement sensor checking the part number is correct. This part number is labelled on the main body of the detector.
- Inspect the gaskets and replace if necessary.
- The sinter assembly will only need to be replaced if it has become blocked by dust or oil. Such blockage causes the response time of the detector to be slow and may affect sensitivity. To remove the

| Description | Part number |
|--|-----------------|
| M20 to 1/2 inch NPT adaptor | MO2125 |
| M20 to 3/4 inch NPT adaptor | MO2281 |
| Gasket 1 | MO4452 |
| Gasket 2 | MO4128 |
| Sinter removal tool | MO1614 |
| Collector Cone | CO1051 |
| Ceiling Mounting Bracket | MO1401 |
| Weatherproof Cap | CO1442 |
| Replacement 'CRO-Mag' | CO1697 |
| 96HD sensor housing complete with sensor | SO1749* |
| Replacement sensor | SO1673* |
| Sinter assembly | SO1781 |
| Amplifier | SO1865 |
| Terminal board | SO1846 |
| Relay board | SO1847 |
| Location No. 243 | Contact Crowcon |
| Calibration gas | Contact Crowcon |

* Flamgard Plus may be fitted with a range of pellistor sensors depending on the specific application. The correct spare sensor part number is itemised on the sensor housing label.

17

5. SPECIFICATION

| | |
|-----------------------------|--|
| Dimensions | 200 x 115 x 115 mm (8" x 4 1/2" x 4 1/2") |
| Weight | 2.2 kg (4.8 lbs) |
| Material | 96HD sensor housing: 316 Stainless steel Junction box: Marine grade alloy |
| Temperature range | -10-55°C (14-131°F) |
| Humidity range | 0-99% RH, non condensing |
| Ingress protection | IP65 |
| Explosion protection | Flameproof |
| Approval codes | Ex II 2 G Ex d IIC T6 Gb (+5°C) |
| Safety Cert No. | SIra3ATEx1124 |
| Standards | EN60079-0, EN60079-1: 2007, UL2279 |
| Zones | Certified for use in Zone 1 or Zone 2 areas. (see area classifications section) |
| Gas groups | IIA, IIB, IIC |
| Operating voltage | 12-30Vdc |
| Operating current | Relay version: 210 mA (maximum) Non-relay version: 160 mA (maximum) |
| Detector output | 0 mA = Fault 2 mA = Inhibit (4 mA option) 4-20 mA = 0-100% LEL 24 mA = Over range |
| Relays outputs | 2 x Alarm relays SPNO (SPNC option) 1 x Fault relay SPNC (SPNO option) |
| Contact rating | 1 A @ 30 Vdc |

13

Diagram 4: 96HD assembly

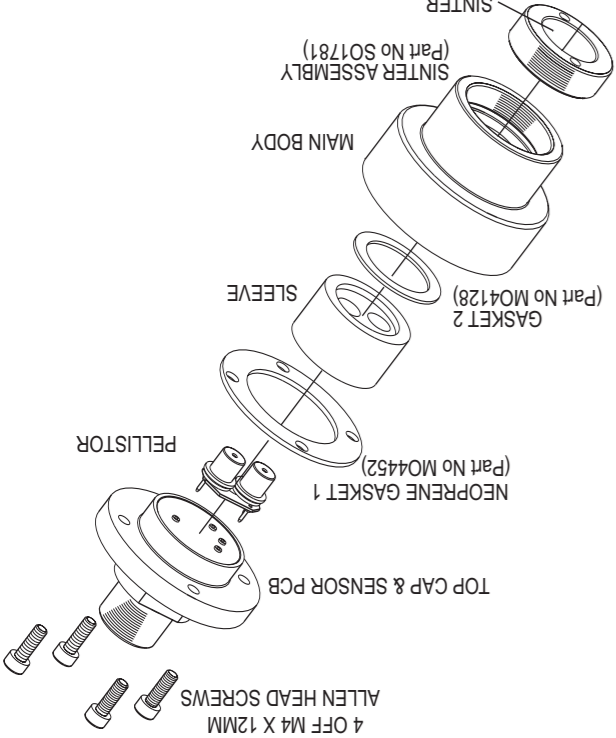

18